

# USE AND MAINTENANCE MANUAL



*"Original instructions"*  
2021-07 rev 17

**LUBE INDUSTRIES srl**

via dell'industria 4

62010 Treia (MC) ITALY

P.IVA 01504060433

TEL 07338401

[info@cucinelube.it](mailto:info@cucinelube.it) - [www.cucinelube.it/en/](http://www.cucinelube.it/en/)

[info@creokitchens.it](mailto:info@creokitchens.it) - [www.cucinecreo.it/en/](http://www.cucinecreo.it/en/)



GRUPPOLUBE



## 4 PREMISE

## 6 INTRODUCTION

## 6 INTENDED USE

## 6 INCORRECT USE

## 7 USAGE ENVIRONMENT

## 8 SAFETY

8 *safety check*

9 *maximum loading capacity*

## 12 KITCHEN DESCRIPTION

12 *primary element composition (base unit, tall unit, wall unit)*

13 *components description*

## 14 USE/INSTRUCTIONS

14 *general precautions*

14 *doors and hinges*

15 *handleless kitchens*

15 *appliances*

17 *sink*

17 *specific surfaces*

18 *wall units with mechanisms*

19 *back panels*

19 *tables and chairs*

19 *worktops*

## 20 CLEANING

20 *premise*

20 *products to avoid (on all types of surfaces)*

21 *ordinary cleaning (on all types of surfaces)*

22 *for the most resistant stains ...*

23 *good advices for cleaning some specific surfaces*

## 26 MANTEINANCE/ADJUSTMENTS

26 *how to unhook the shelf*

26 *how to disassemble / replace the door (only RH – LH opening doors)*

27 *how to adjust the hinge (only RH – LH opening doors)*

28 *how to repair the Fenix laminate worktop*

28 *how to remove / replace the drawer/ deep drawer*

29 *how to adjust the drawer / deep drawer*

30 *how to unhook the plinth*

## 31 DISPOSAL

## 31 ASSISTANCE

## 32 GLOSSARY

# PREMISE

The consumer is obliged to scrupulously respect the given indications and advices; any damage due to improper use of the products or maintenance and cleaning other than those described in this manual will not be subject to warranty replacements.

With the addition of new elements in a kitchen previously installed, it is possible to highlight differences in shades due to the normal oxidation processes of the materials. Therefore these differences cannot be grounds for complaint.

**Make sure** that the assembly is carried out by qualified staff and in any case do not make any modifications to the cabinets that could compromise the stability of the structure. In fact, there may be dangers such as overturning or failures in the event of incorrect installation.

**It is forbidden** to move or install the kitchen autonomously, if it (or some parts) has not yet been installed. Therefore, wait for these operations to be carried out by authorized and qualified staff.

**Check** that the kitchen, once installed, corresponds with the order made and that it has no defects.

**Check** that the backsplash (or the back panel) and the worktop are assembled with their hardware, glued with silicone and insulated in a proper way

**Contact** your authorized LUBE / CREO dealer for any problem / assistance.

# INTRODUCTION

This use and maintenance manual has been prepared to instruct and facilitate the consumer in the proper and intended use for which the kitchen is designed, as well as its maintenance and correct cleaning.

Consult this manual entirely and carefully, for a correct and appropriate use of the kitchen and for healthy and comfortable surroundings.

Keep this manual for future reference.

This use and maintenance manual was written taking into account the provisions of Legislative Decree 206 of 2005 - Consumer Code, Italian legislation set up to protect the consumer.

# INTENDED USE

Each kitchen is designed and built to be able to carry out all “cooking” operations in total safety. The kitchen is also useful to provide ergonomically designed spaces (wall units, bases, tall units, etc.) as a storage / pantry.

In this way, the kitchen environment in your home becomes a comfortable and welcoming place, where you can carry out daily actions related to cooking in full ergonomics and organization of space.

# INCORRECT USE

- **Hang / cling / climb** on wall units, columns, shelves, shelves, hoods, doors.
- **Climb** on bases, drawers, deep drawers, worktops, shelves, tables.
- **Prevent** ventilation by placing objects above-behind or under-in front of the refrigerator.
- **Hit** the glass parts.
- **Overload** beyond the allowed weight.
- **Cause** excess heat.

# USAGE ENVIRONMENT

The environment where the kitchen is installed plays an important role for the health and safety of both the kitchen itself and the people who use it.

## UMIDITY

First of all, attention must be paid to internal humidity: for a healthy and comfortable living climate, it is essential that the humidity level remains between 40 and 65% and no more. In case of excessive humidity, in fact, an ideal climate is created for the proliferation of unwanted bacteria and fungal spores, which can cause allergies and infections. Furthermore, problems such as, for example, dimensional variations of the doors and wooden details can occur.

## DIRECT LIGHT

Some kitchen materials (especially wood and lacquered surfaces) can undergo color changes (yellowing) if they are exposed to direct sunlight for a long time.

It is therefore essential to protect the furniture from direct sunlight, using cover panels, for example.

## AIR VENTILATION (UNI 7129:2015 REGULATION)

Inside the kitchen, the amount of air that is consumed by the combustion of gas must necessarily be compensated by an equally large dose that must flow from the outside.

Therefore, in addition to the fixtures already present, at least two other permanent openings are used, facing the external environment: one is functional for ventilation (air outlet) and the other is intended for ventilation (air intake), located near the floor.

In the case of installation of an EXTRACTOR hood, the ventilation hole (outlet) may not be mandatory.

## DANGEROUS AREAS

Even in an environment such as the kitchen there are some components or some “areas” to which particular attention must be paid, as they are sources of potential dangers.

These dangerous areas include:



**Appliances:** in particular hob, oven, dishwasher

WARNING! - DANGER OF BURNS



**Floor:** especially if wet or with slippery objects

WARNING! - DANGER OF SLIPPING / FALLING

# SAFETY

## safety check

LUBE Industries srl carries out daily quality control and safety work on the products manufactured internally in its factories. The same safety checks also concern the products that LUBE industries srl buys from external suppliers and then markets, to meet market needs and comply with the provisions of the Consumer Code: only place safe products on the market (Art. 104- "Obligations of the manufacturer and the distributor").

All the wood-based components of the kitchen take into account the provisions of the Ministerial Decree of 10.10.2008, Ministerial Decree able to regulate the emission of ant aldehyde from wood-based panels and products made with them in living environments.

## declaration of conformity for formaldehyde emission

(pursuant to Ministerial Decree 10.10.2008)

The undersigned Mr PACIFICO SILEONI, representing the company LUBE INDUSTRIES srl, via dell'industria 4 Treia (MC), VAT number 01504060433

hereby declare with exclusive responsibility that

all wood-based components used in the kitchens that the company produces are compliant with: UNI EN 13986:2015 "Wood-based panels for use in construction – Characteristics, evaluation of conformity and marking", exclusively for what indicated at section B1 of the standard referred to "E1 classes of formaldehyde", according to "D.M. 10 ottobre 2008" (formaldehyde emission < 0.1 ppm or < 0.124 mg/m<sup>3</sup>, according to the EN 717-1:2004 standard).

Furthermore declare that the furniture structure elements are compliant with EPA TSCA Title VI (for LUBE, CREO and BORGIO ANTICO collections) and with the Japanese JIS A 1460 standard for F\*\*\*\* classification (for LUBE and CREO collections).

Treia, May 9th 2019

  
Pacifico Sileoni

## maximum loading capacity

The maximum loading capacity of the following items refers to tests made according to UNI 11663:2017 and UNI EN 14749:2016 standards.

### TOP/BOTTOM (WALL UNIT)

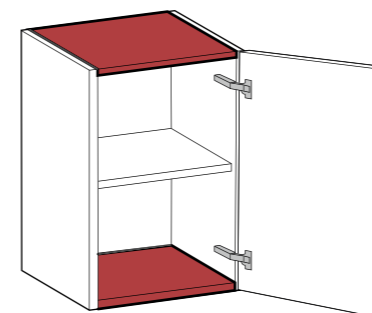

DEPTH (cm)	WIDTH (cm)	MAX LOAD
31/34	45/60/90/120	<b>25 kg</b>

### SHELF (WALL UNIT)

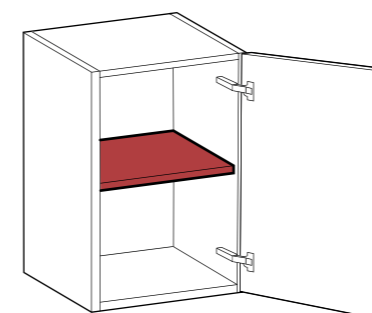

MATERIAL	DEPTH (cm)	WIDTH (cm)	MAX LOAD
<b>CHIP BOARD</b>	31/34	UP TO 120	<b>20 kgs</b>
<b>GLASS</b>	31/34	45/60	<b>15 kgs</b>
<b>GLASS</b>	31/34	90/120	<b>10 kgs</b>

### PLATE RACK UNIT GRILL

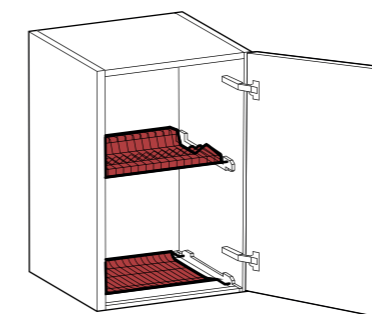

DEPTH (cm)	WIDTH (cm)	MAX LOAD
23	45/60/90	<b>24 kgs</b>
23	120	<b>20 kgs</b>

### SHELF (OPEN UNIT)

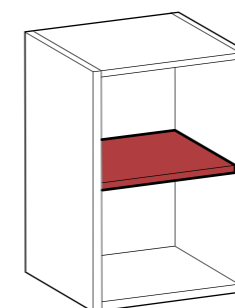

MATERIALE	PROFONDITA' (cm)	LARGHEZZA (cm)	CARICO MASSIMO
<b>CHIPBOARD THK. 14 mm</b>	31/34	UP TO 120	<b>10 kgs</b>
<b>LAQUERED/VENEERED/PET THK. 18 mm</b>	31/34	UP TO 120	<b>20 kgs</b>
<b>METAL</b>	31/34	UP TO 120	<b>8 kgs</b>

### SHELF (BASE UNIT/COLUMN)

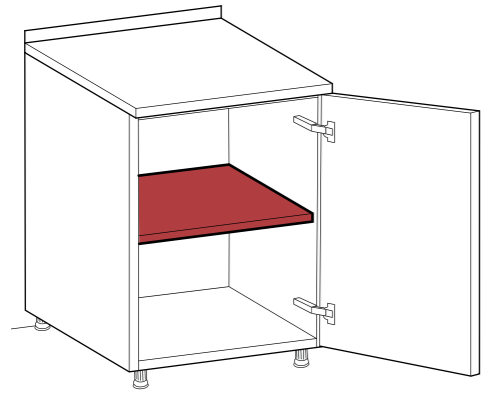

MATERIAL	DEPTH (cm)	WIDTH (cm)	MAX LOAD
CHIPBOARD	UP TO 60	UP TO 120	35 kgs
GLASS	UP TO 60	30/45/60	15 kgs
GLASS	UP TO 60	90/120	10 kgs

### HANGING BASE UNIT

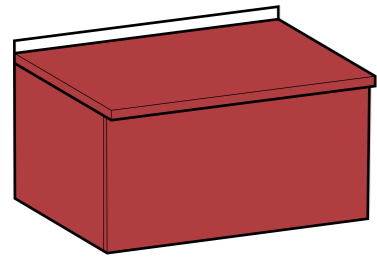

DEPTH (cm)	WIDTH (cm)	MAX LOAD
UP TO 60	60/90/120	120 kgs

### EXTENDABLE ELEMENT (DRAWER/DEEP DRAWER)

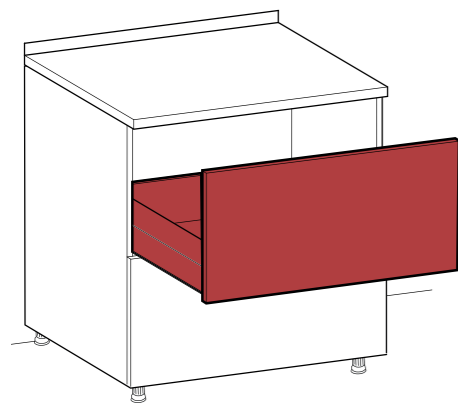

DEPTH (cm)	WIDTH (cm)	MAX LOAD
60	UP TO 120	50 kgs
REDUCED	UP TO 120	30 kgs

*the maximum loading capacity indicated are inclusive of the weight of the drawer/deep drawer*

### SHELF

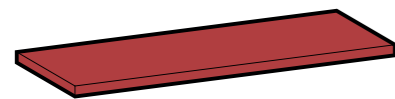

MATERIAL	DEPTH (cm)	WIDTH (cm)	MAX LOAD
COATED	UP TO 61	-	20 kgs/m
METAL	-	UP TO 80	8 kgs/m

### CODE ELEMENT - SHELF

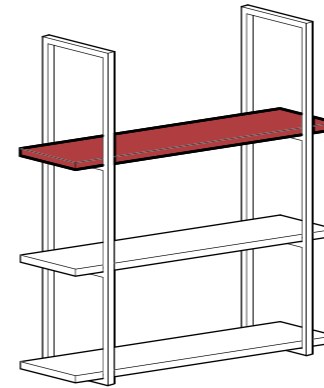

DEPTH (cm)	WIDTH (cm)	MAX LOAD
-	60/90/120	25 kgs

### LIVING

#### SHELF (WALL UNIT)

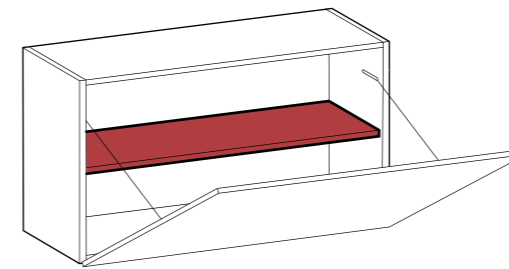

DEPTH (cm)	WIDTH (cm)	MAX LOAD
31	UP TO 120	20 kgs

#### SHELF (BOOKCASE)

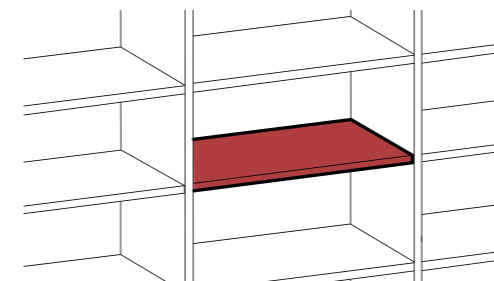

DEPTH (cm)	WIDTH (cm)	MAX LOAD
31	-	25 kgs

### EXTENDABLE ELEMENT (DEEP DRAWER)

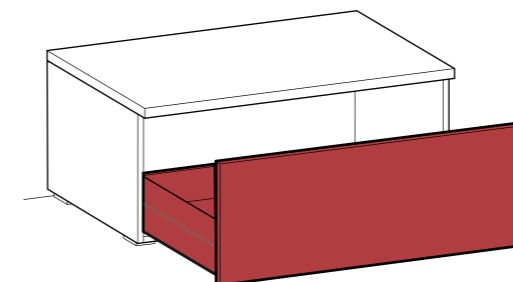

DEPTH (cm)	WIDTH (cm)	MAX LOAD
48	UP TO 120	30 kgs

*the maximum loading capacity indicated are inclusive of the weight of the deep drawer*

# KITCHEN DESCRIPTION

The kitchen is designed and built to be used, cleaned and undergo the necessary maintenance without these operations exposing people to risks, if carried out under the conditions envisaged, also taking into account reasonably foreseeable incorrect use.

A kitchen is normally composed of primary elements (base units, tall units, wall units), worktops, appliances and other components that can be added according to tastes and needs, such as tables, chairs, complements (shelves, open units, back panels, cornices, cover panels, etc.), various accessories (lights, under-wall units, etc.), etc.

## composition of the primary element (base unit, tall unit, wall unit)

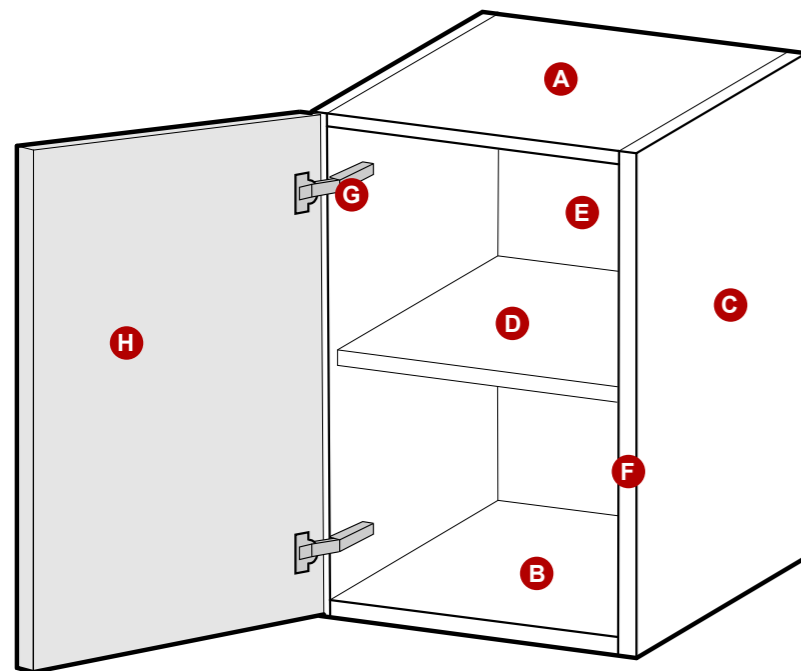

- A** Top panel
- B** Bottom
- C** Side panel
- D** Shelf
- E** Back panel
- F** Edge
- G** Hinge
- H** Door

## description of components

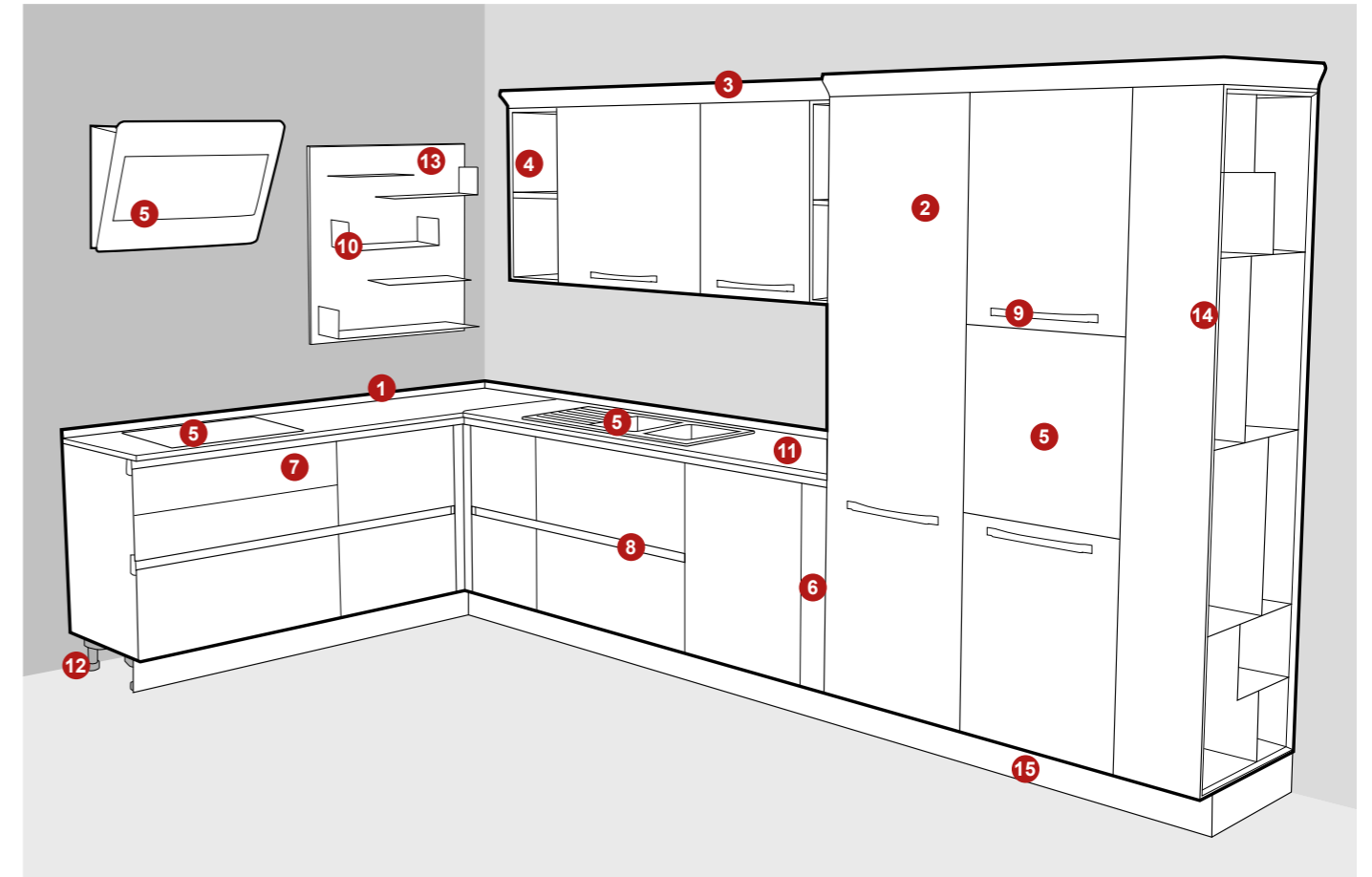

- 1** Backsplash
- 2** Door
- 3** Cornice
- 4** Open unit
- 5** Appliances (oven, microwave, hob, hood, fridge, dishwasher, washing machine, dryer)
- 6** Cover panel
- 7** Drawer/deep drawer front
- 8** Finger rail
- 9** Handle
- 10** Shelf
- 11** Worktop
- 12** Feet
- 13** Splashback
- 14** End unit
- 15** Plinth

For further information on the individual components go to "GLOSSARY" - page 32

# USE/INSTRUCTIONS

## general precautions

- DRY SURFACES AND EDGINGS IMMEDIATELY AFTER USE. Especially in the case of cabinets adjacent to appliances to avoid excess heat, drops of water and steam such as:
  - Hob: when in operation can cause steam on adjacent wall units;
  - Oven: emits steam when is working and when you open it;
  - Dishwasher: when opened at the end of washing gives off steam;
  - Hood: condensation may form near it.
- AVOID excess of heat and humidity on edges, joints and flat surfaces.
- DO NOT UNDERGO THE SURFACES (especially those of worktops and sinks) to direct contact with sources of high heat (pots, coffee makers, irons, etc.), as to strong IMPACT or contact with sharp objects (knives, scissors etc. ) or blunt (tools, bottles, pots, etc.).
- PROTECT FURNITURE FROM DIRECT SUNLIGHT: DO NOT EXPOSE surfaces directly and prolonged to sunlight (e.g. protect them using curtains). A kitchen furniture exposed in a different way to the sun radiation can change shades unevenly.
- NEVER leave food in direct contact on shelves / worktops.
- AVOID EXCESSIVE SPILLING OF LIQUIDS that could penetrate inside the cabinets and damage materials not resistant to this type of stress.

## doors and hinges

- NEVER FORCE the door opening angle.
- DO NOT HOLD ON to the doors when they are open.
- DO NOT UNDERGO the internal part of the doors to contact with stains and unsuitable cleaning products.
- DO NOT LEAVE OPEN, inside the container furniture, packs or bottles of detergents or other chemical products or toxic / corrosive substances (acetone, ammonia, trichloroethylene, bleach, caustic soda, muriatic acid, thinner etc.) which could cause oxidation over time.

## handleless kitchens



**WARNING! - DANGER OF CRUSHING:** when closing the drawer / deep drawer, be careful not to pinch your fingers

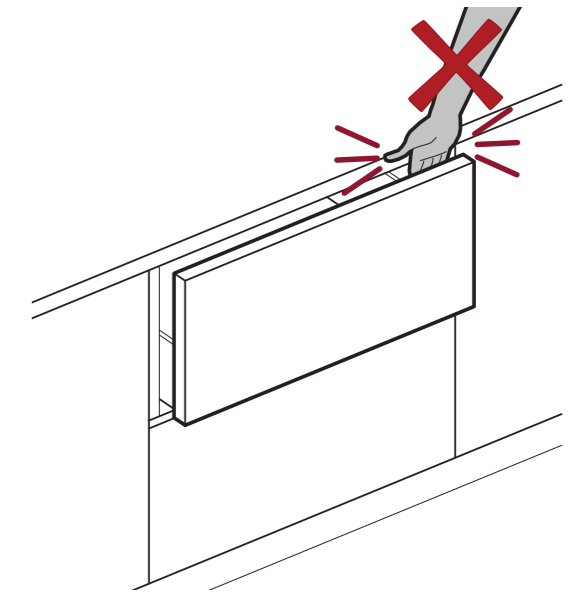
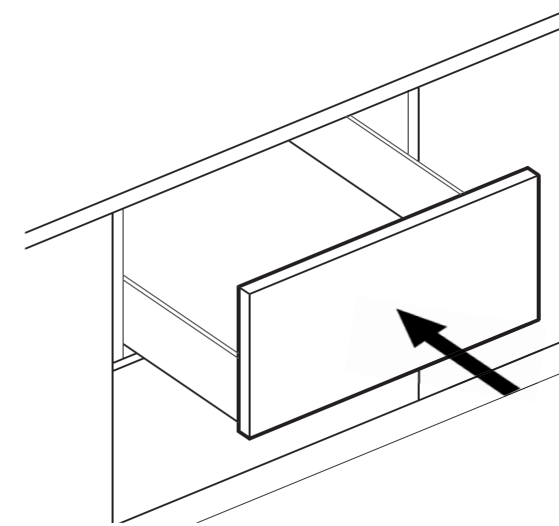

## appliances

- PERFORM a PERIODIC CHECK of the appliances (CONSULT THE RELEVANT USE AND MAINTENANCE MANUALS).
- BEFORE servicing the appliances, always consult the relative manuals.
- DO NOT carry out maintenance on appliances without first disconnecting the plug or switch.
- DO NOT USE adapters and multiple sockets, the appliance plug must be the only one connected to the socket to avoid overheating and create short circuits. In addition, the kitchen electrical system must have a general differential switch, able to control a single safety switch for each appliance.
- DO NOT TAMPER or modify the electrical parts. For any need, contact qualified personnel.
-  **WARNING! - DANGER OF ELECTRIC SHOCK:** AVOID operating or touching the appliances when you are barefoot and when the floor is wet.
- FOR ANY problem call for assistance (see appliance manual).

## HOOD

- Always TURN ON the hood every time you cook, in particular turn on 5 minutes before starting to cook and turn off 15 minutes after you finish.



- REGULAR MAINTENANCE of the hood (filter change and cleaning) is essential for the durability of the kitchen cabinets. That is why we refer to the specific instructions of the various manufacturers.
- Turn on the hood by setting an APPROPRIATE POWER to the heat generated by the hob.
- The hood protection front (models for built-in wall units) must be ALWAYS OPEN while the hood is operating.

## REFRIGERATOR TALL UNIT

- DO NOT PLACE anything ABOVE-BEHIND and UNDER-IN FRONT of the refrigerator tall unit. In fact, for a correct operation the refrigerator tall unit requires continuous ventilation, that is guaranteed by a special pre-drilled plastic bottom that allows the air flow to enter from the underside of the cabinet door and to exit from the upper part.

## OVEN

- MINIMIZE THE OPENING OF THE OVEN when it is working, to avoid the emission of hot steam that could, in the long run, compromise the surfaces of the surrounding furniture.

## DISHWASHER



**WARNING! – RISK OF BURNS: wait for the appliance cooling before opening it.**

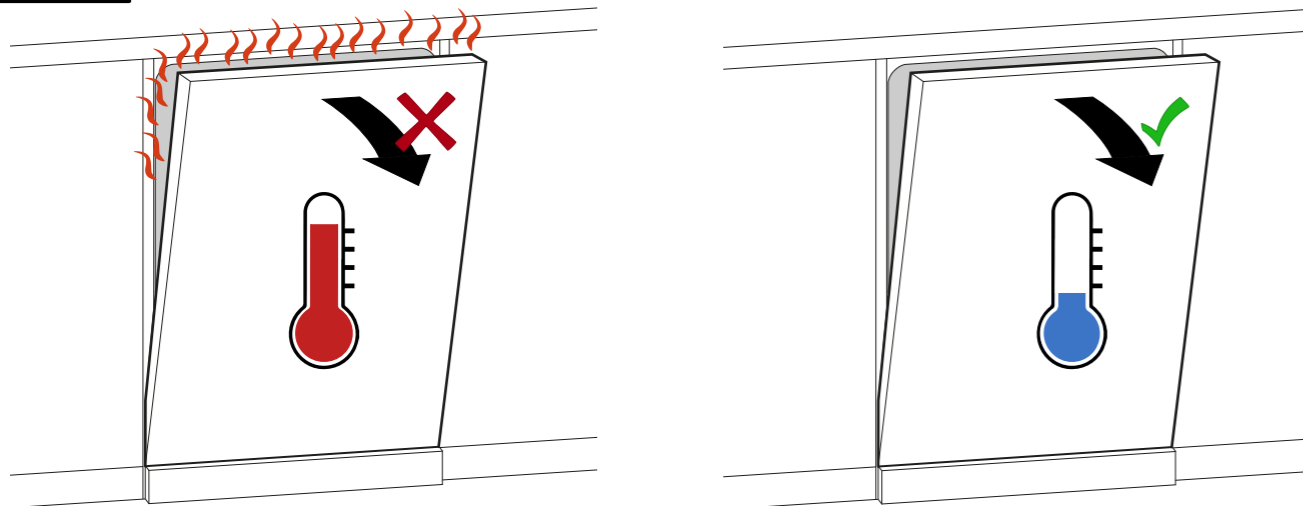

*Some dishwashers have automatic opening at the end of washing. In this case, it is not necessary to wait to open the door, because as long as the appliance has not cooled down, it remains blocked. Once unlocked, you can then proceed with the opening without danger.*

## HOB

- ALWAYS USE LIDS and pots suitable for containing vapors.
- NEVER leave the stove on without a pot on it.

## sink

- DO NOT POUR boiling liquids directly into the sink without first opening and running cold water over the bottom of the tub.
- DO NOT PLACE pots removed directly from the fire or hot and overheated materials or materials that have been in direct contact with the fire, in order to avoid thermal shock (about that, always use sub-pots).
- ALWAYS USE special chopping boards and do not work directly on the sink
- DO NOT LEAVE packages and open bottles of detergents or other chemicals under and near the sink to avoid oxidation and corrosion due to fumes.

## specific

### STAINLESS STEEL (SINK-WORKTOP-SPLASHBACK)

- DO NOT LEAVE open packages and bottles of detergents or other chemicals near these surfaces, to avoid oxidation and corrosion due to fumes.
- DO NOT leave rusty iron objects on the surface for a long time.
- DO NOT DRAG pots on the stainless steel worktop. Lift and move them during normal kitchen operations.
- DRY liquids to avoid stains and oxidations.
- DO NOT PLACE hot objects without protections, to avoid deformations.

### GRES PORCELAIN (WORKTOP-DOORS-SPLASHBACK)

- DO NOT UNDERGO to shocks the most delicate points such as edges.

### LAMINATE/MELAMINE (WORKTOP-DOORS-SINKS-SHELVES-SPLASHBACKS)

- ATTENTION TO EDGES AND JOINTS: if neglected or undergo to excess heat, water and humidity, they can weaken and facilitate the occurrence of anomalies.
- KEEP SURFACES always dry, especially near the joints, to protect them from the risks associated with excess water and humidity.
- AVOID contact with staining substances such as wine, coffee, fruit juices, bleaches, chemical or aggressive products (which contain chlorine, acetone, trichloroethylene, ammonia, pure alcohol, stain removers ...) which can cause discoloration of the laminate.
- DO NOT SUBJECT SURFACES to direct contact with sources of high heat (pots, coffee makers, etc.). In the presence of a laminate backrest close to the hob, dose the flame of the stove in such a way as not to damage the backrest.

## WOOD (WORKTOP-DOORS-TABLES-CHAIRS-SHELVES)

- AVOID prolonged contact of wooden surfaces with damp objects (bottoms of wet glasses, tablecloths, cold drinks) which can cause swelling.
- In case of contact with water or steam, DRY IMMEDIATELY and carefully.

## CEMENT MORTAR FINISH (DOORS-SPLASHBACKS-SHELVES)

- PAY particular attention to the corners and edges, especially for the darker shades (as any scratches or wear would be more noticeable).

## PVC-PET-PP-ACRYLIC-POLYMER PLASTIC MATERIALS (DOORS-CHAIRS-STOOLS-SHELVES-PLINTHS)

- PROTECT surfaces and edges from steam / heat as they could come unstuck (e.g. switch on the hood, open the front of the built-in hood, etc.).

## STONE AND AGGLOMERATES (SINK-WORKTOP-SPLASHBACKS)

- PERFORM REGULARLY (1 time a year) a water repellent treatment by calling a technician specialized in working the stones, who will carry out the treatment.
- AVOID DIRECT CONTACT with staining and coloring substances, acid and even fatty substances: marbles and granites are delicate materials and are easily stained.  
staining substances: coffee, wine, tea, bleach, anti-limescale, etc.  
acid substances: lemon, vinegar, tomato, cola, fruit, citrus fruits, etc.  
fatty substances: oil, sauces, etc.

## wall units with mechanisms



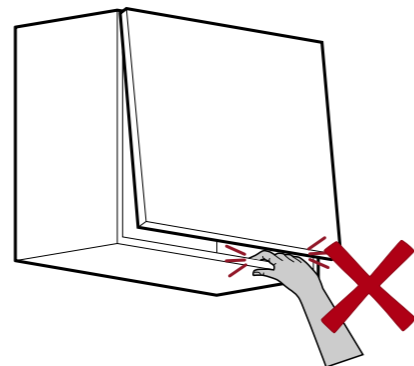
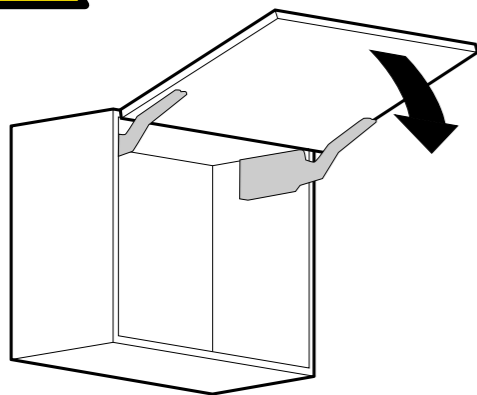

**WARNING! - DANGER OF CRUSHING:** when closing the door, be careful not to pinch your fingers.



## back panels

- DO NOT leave bottles of oil or vinegar in contact with the back panels of cabinet, as the latter could stain itself.

## tables and chairs

- CHECK periodically that the bolts used to secure the legs are tight.
- DO NOT use the chairs for EXTERNAL areas, as they are not suitable.
-  **WARNING! - DANGER OF FALL:** DO NOT climb on the table and / or on the chair.
-  **WARNING! - DANGER OF FALL:** Always use the chairs with the four legs resting on the floor

## worktop

- DO NOT PLACE pots removed directly from the fire or hot and overheated materials, or materials that have been in direct contact with the fire, in order to avoid thermal shock (about that, always use sub-pots).
- Always use special chopping boards and do not work directly on flat surfaces.
-  **WARNING! - DANGER OF FALL:** DO NOT UNDERGO to excessive concentrated loads MORE THAN 50 kg (e.g. do not stand on the worktop).

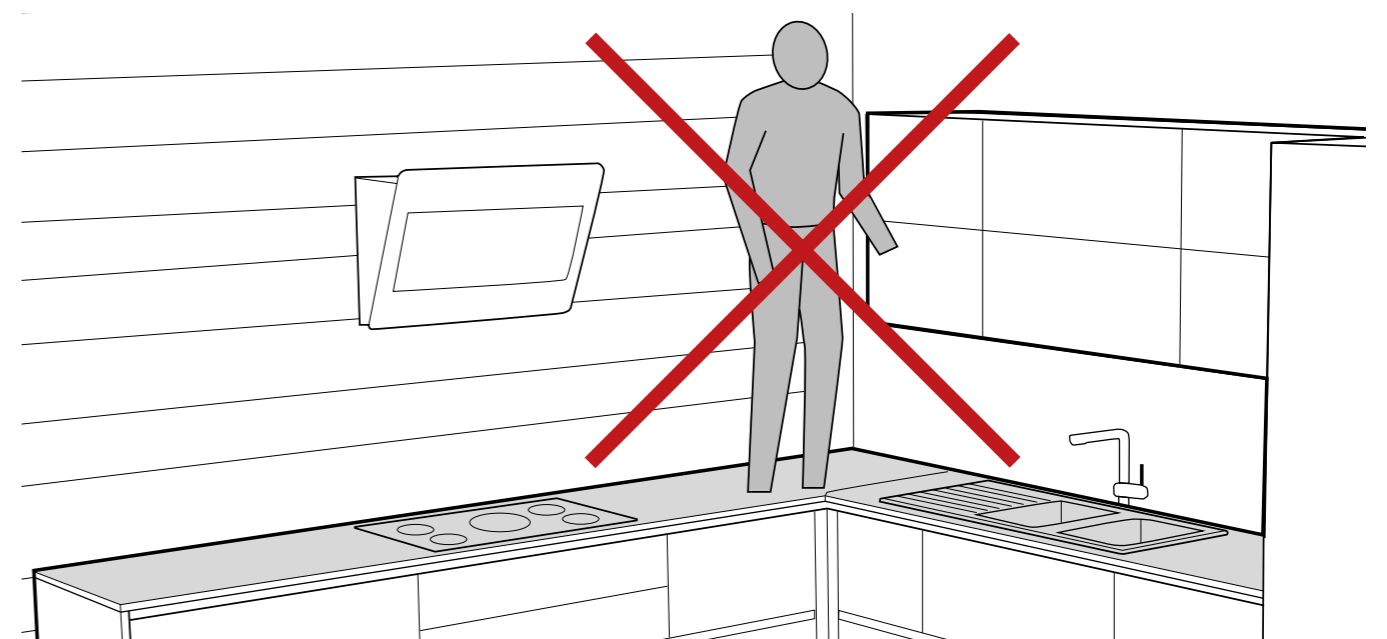

# CLEANING

## premise

- STAINS (all kinds of) MUST BE CLEANED IN A TIMELY, when they are still fresh.
- STRICTLY PROHIBITED dynamic cleaning (e.g. excessive rubbing) as the materials / surfaces could be deformed.
- NEVER USE rough cleaning supports (e.g. abrasive sponges, steel wool, abrasive creams or cleaning products in powder form and similar).
- NEVER USE woolen and paper rags.
- NEVER USE cleaning tools that produce steam at high temperatures.
- ALWAYS DRY SURFACES AT THE END OF THE CLEANING. Never allow stagnation of water / humidity and in general stagnation of liquids on doors, structures or worktops, as they could cause detachment near the edges or absorption and unpleasant stains.
- REMOVE traces of cleaning products with a dry cloth to avoid streaks.
- ATTENTION to staining substances (e.g. wine, coffee, fruit, etc.) and aggressive substances (chlorine, alcohol, acetone, trichlorethylene, stain removers, etc.).

## products to avoid (on all surfaces)

- acetone
- all kinds of acids
- alcohol
- ammonia
- anti-limescale
- bleach
- detergents containing chlorine
- paint thinners
- descaling
- ink
- solvents and derivatives
- trichloroethylene
- waxes or waxing products
- degreasers
- aggressive detergents, anti-limescale condensed (e.g. Viakal)



## ordinary cleaning (valid for all surfaces)

Ordinary cleaning must be carried out as follows:



**1** clean the surfaces with a microfiber cloth wet with water and well squeezed



**2** dry well with a other microfiber cloth dry, to avoid halos

### TO OBTAIN AN OPTIMAL RESULT:

use water and a neutral detergent (spray or liquid):

*RECOMMENDATION: Before using the detergent, test the product by using it in a hidden area (inside the door, an edge or not visible areas).*

**NEUTRAL SPRAY CLEANER** (e.g. glass cleaner, multi-surface product etc.):

- 1- **wet** a microfiber cloth with water and wring it out well
- 2- **spray** the detergent on the microfiber cloth and NOT directly on the surface
- 3- **clean** the surfaces by passing the cloth in circular movements
- 4- **rinse** again the surfaces with a microfiber cloth, clean and moistened with only water
- 5- **dry well** with another dry microfiber cloth placing particular attention on the edges.



**NEUTRAL LIQUID DETERGENT TO DILUTE** (e.g. dishwashing detergent):

- 1- **dilute** the detergent with water (Proportion 1:10, for example 0.1 liter of cleaning product and 1 liter of water)
- 2- **wet** a microfiber cloth with the solution obtained and wring it out
- 3- **clean** the surfaces by passing the cloth in circular movements
- 4- **rinse** again the surfaces with a microfiber cloth, clean and moistened with only water
- 5- **dry well** with another dry microfiber cloth placing particular attention on the edges.



## for the most resistant stains...

If ordinary cleaning is not enough, it is possible to proceed, depending on the nature of the staining agent, with specific cleaning / detergent techniques for the surface to be treated.

In this regard, we recommend to:

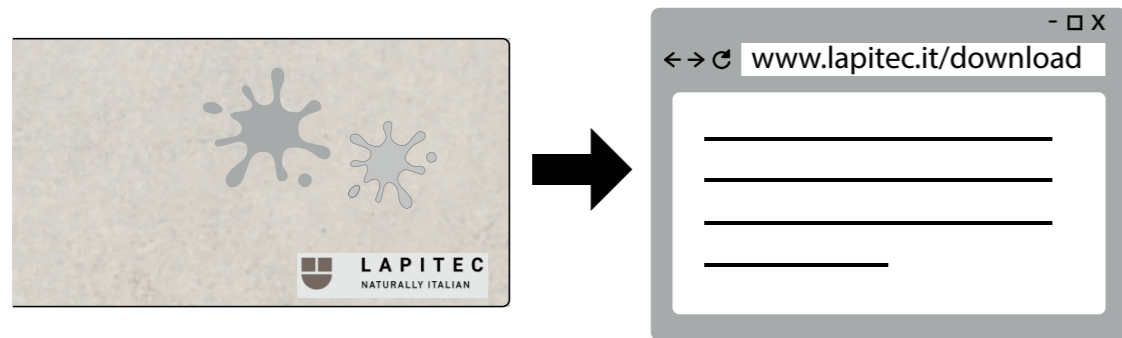

If helpful, consult the website of the manufacturer of the surface to be treated.

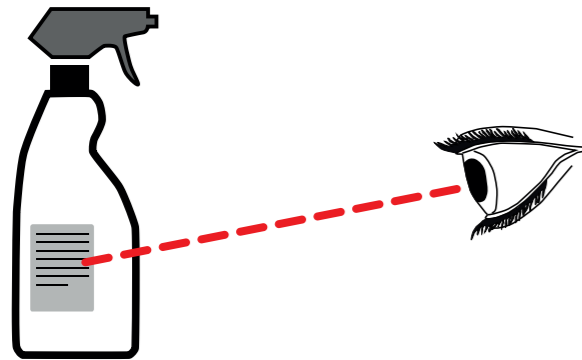

Before applying, always read the label on the detergent, making sure it is suitable for the surface to be treated

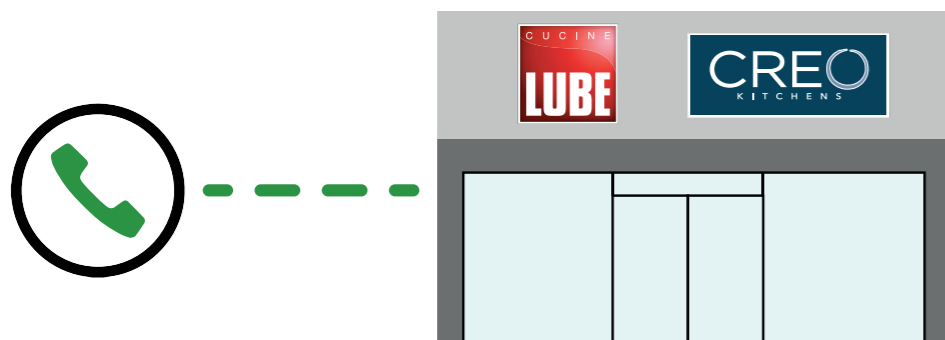

In case of any problems, contact your authorized LUBE / CREO dealer

## advice for cleaning some surfaces

### STAINLESS STEEL (WORKTOP-SINKS-SPLASHBACKS)

- Stainless steel surfaces tend to get stained with the limestone contained in the water. There are specific products on the market that remove stains with little effort. DO NOT USE detergents containing chlorine or rough cleaning cloths.
- **RUST STAINS:** These stains can be eliminated with an energetic use of cream detergents (eg Stahl-fix or similar products) with a normal non-abrasive sponge. The product should be act for a few minutes and then rinse thoroughly and dry thoroughly.

### ALUMINUM (RISERS-DOORS-FINGER RAILS-OPEN UNITS-SPLASHBACKS-PLINTHS)

- For the cleaning of satin and polished aluminum there are specific products available in hardware stores and specialized shops.

### COMPOSITE (WORKTOP-SPLASHBACKS)

- If ordinary cleaning is not enough, switch to cleaning with a creamy detergent such as "CIF Ammonical" cream or more aggressive detergents to be removed immediately using a sponge; do not allow these products to act on the hob for a long time as they could leave marks if they dry out. Then rinse with a sponge dampened with water and dry well with a soft dry cloth.

### CORIAN (WORKTOP-SPLASHBACK)

- Many damages due to impacts, heat or chemicals can usually be repaired on site, fully restoring the original, regular and hygienic appearance to the surface. For repairs please contact your LUBE / CREO dealer or contact the DuPont™ Corian® Warranty Center.

### LACQUERED (DOORS-SHELVES)

- In case of limited and small-sized chipping, it is possible to intervene with a special touch-up. Using a small brush, apply the right amount of paint to cover the damaged area. You can order the touch-up kit from your authorized LUBE / CREO dealer.

## LAMINATE/MELAMINE (WORKTOP-DOORS-SINKS-SHELVES-SPLASHBACKS)

- In case of limescale stains it is possible to use products containing weak acids (acetic acid at 10/15% max and diluted citric acid) or lukewarm water, and bicarbonate in case of light traces.
- In case of stubborn limestone, the use of a solution of water and cooking vinegar in the affected part is allowed, leaving it to act for a maximum of 5 minutes and rinsing immediately afterwards. If the limestone persists, repeat the operation.
- Ink stains can be treated with denatured alcohol and a soft cloth, but generally, alcohol must be used with caution because it is too aggressive.

## HPL COMPACT (SINKS)

- For white HPL Compact, you can also use hydrogen peroxide or bleach (at 3% in max volume and contact time not exceeding 10 minutes).
- To maintain the original shine and prevent dirt and limescale from settling in the bowl:
  - 1- We recommend the treatment of all parts with silicon polish for furniture (in Italy there is "PRON TO" spray), because it promotes the outflow of water and this application must take place by means of small sprays at intervals of 15/20 seconds.
  - 2- After a few moments, wipe with a dry cloth over the entire surface of the bowl (after this treatment avoid direct contact with food).
- For the corners, which are increasingly difficult to clean, you can use a little of bleach (contact time not exceeding 10 minutes) given with a brush.
- If there is a need to use a substance plunger or drain cleaner, limit the contact of the liquid to the surface of the drain only without involving the laminate.
- In the case of stubborn limestone, you can use cooking vinegar in the affected part, leaving it to act for a maximum of 5 minutes and rinsing abundantly immediately after. If the limestone persists, repeat the operation.
- ADVICE: Once or twice a week, do a beauty treatment on your sink. Remove from the sink all oil or grease residues from normal food preparations, by using a detergent or a solution for solid surfaces. Spray a solution consisting of 3/4 of bleach and 1/4 of water on the sink and leave to act for a few hours or overnight. The exposure time should be limited to 16 hours. In the morning, rinse and clean with a damp cloth. The sink will be perfectly clean with very little effort.

## FENIX NTM (WORKTOP-DOORS-SINKS-SHELVES-SPLASHBACKS)

- In the presence of traces of dirt resistant to normal household detergents, use non-aggressive aromatic solvents (acetone).
- In the presence of micro-scratches, please follow the repair instructions (by means of heat source and magic sponge) given in the chapter "MAINTENANCE / ADJUSTMENTS" on page. 26.
- Surface defects caused by scratches can be removed either with the heat or with the magic sponge that you can request from your authorized LUBE / CREO dealer.

## PVC-PET-PP-ACRYLIC-POLYMER PLASTIC MATERIALS (DOORS-CHAIRS-STOOLS-SHELVES-PLINTHS)

- Plastics, as a rule, attract dust because of their electrostatic charge; therefore, it is advisable to treat them with an antistatic agent to be sprayed and distributed by using a soft cloth.
- In the case of ACRYLIC doors, any scratches (if not deep) can be eliminated with a simple polishing operation through a special repair kit which can be ordered from your authorized LUBE / CREO dealer.

## STONE AND AGGLOMERATES (SINK-WORKTOP-SPLASHBACKS)

- Avoid non-specific liquid detergents.
- Scratches can be mitigated by using floor wax.
- Any streaks or stains (limestone type) can be removed by rubbing with a mixture of bicarbonate and water, leaving it to act for a few minutes and then cleaning with a normal damp sponge.

## WOODEN OR VENEERED SURFACES

- Absolutely avoid non-specific detergents and sprays as they could damage the surface painting layer.

*For further information on the individual surfaces go to "GLOSSARY" - page 32*

# MANTEINANCE/ ADJUSTMENTS

## how to unhook the shelf

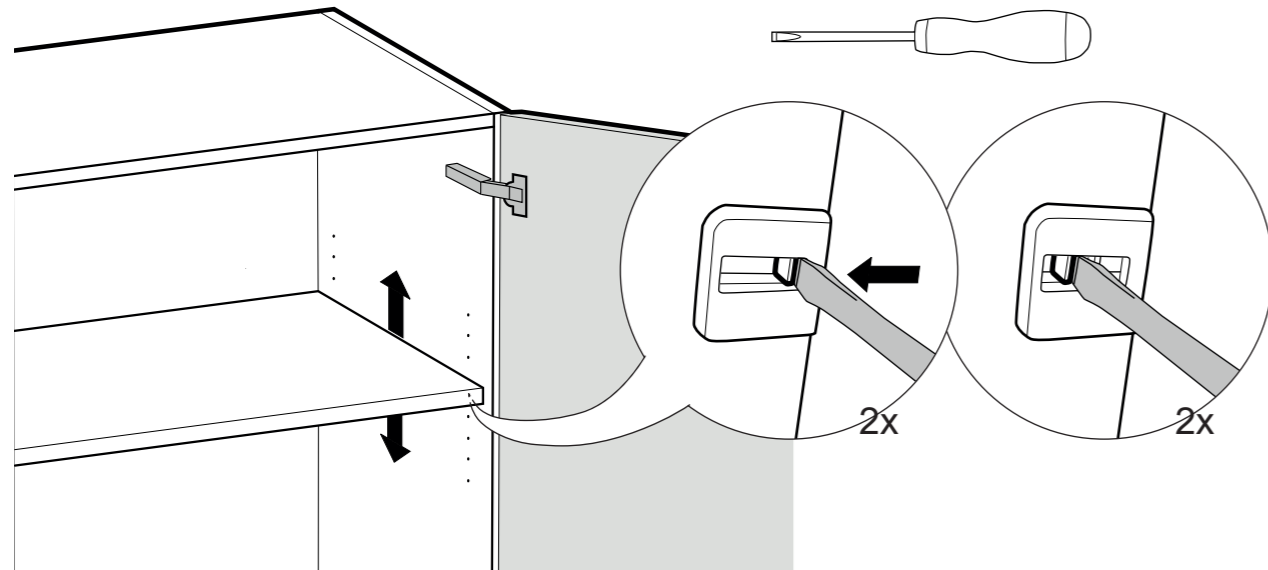

## how to disassemble / replace the door (only RH – LH opening doors)

 Attention to the weight of the door! For too much heavy doors (e.g. column doors) act in two people

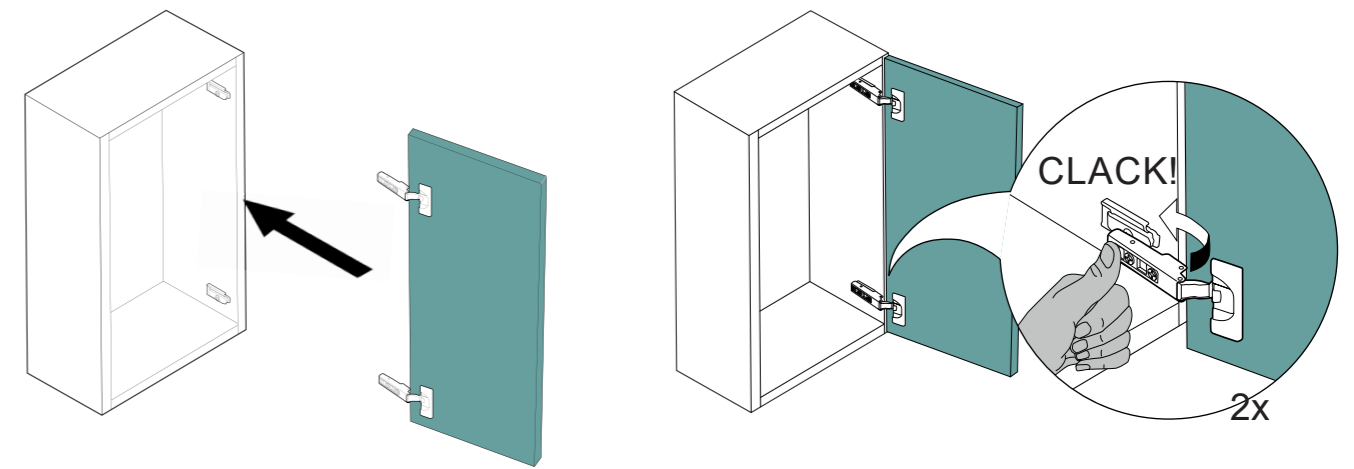
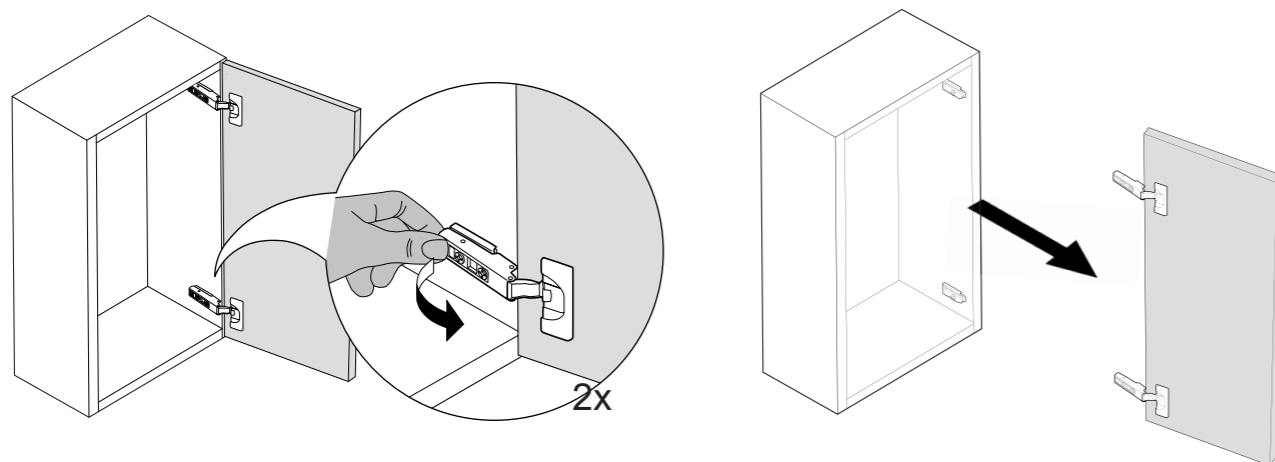

## how to adjust the hinge (only RH – LH opening doors)

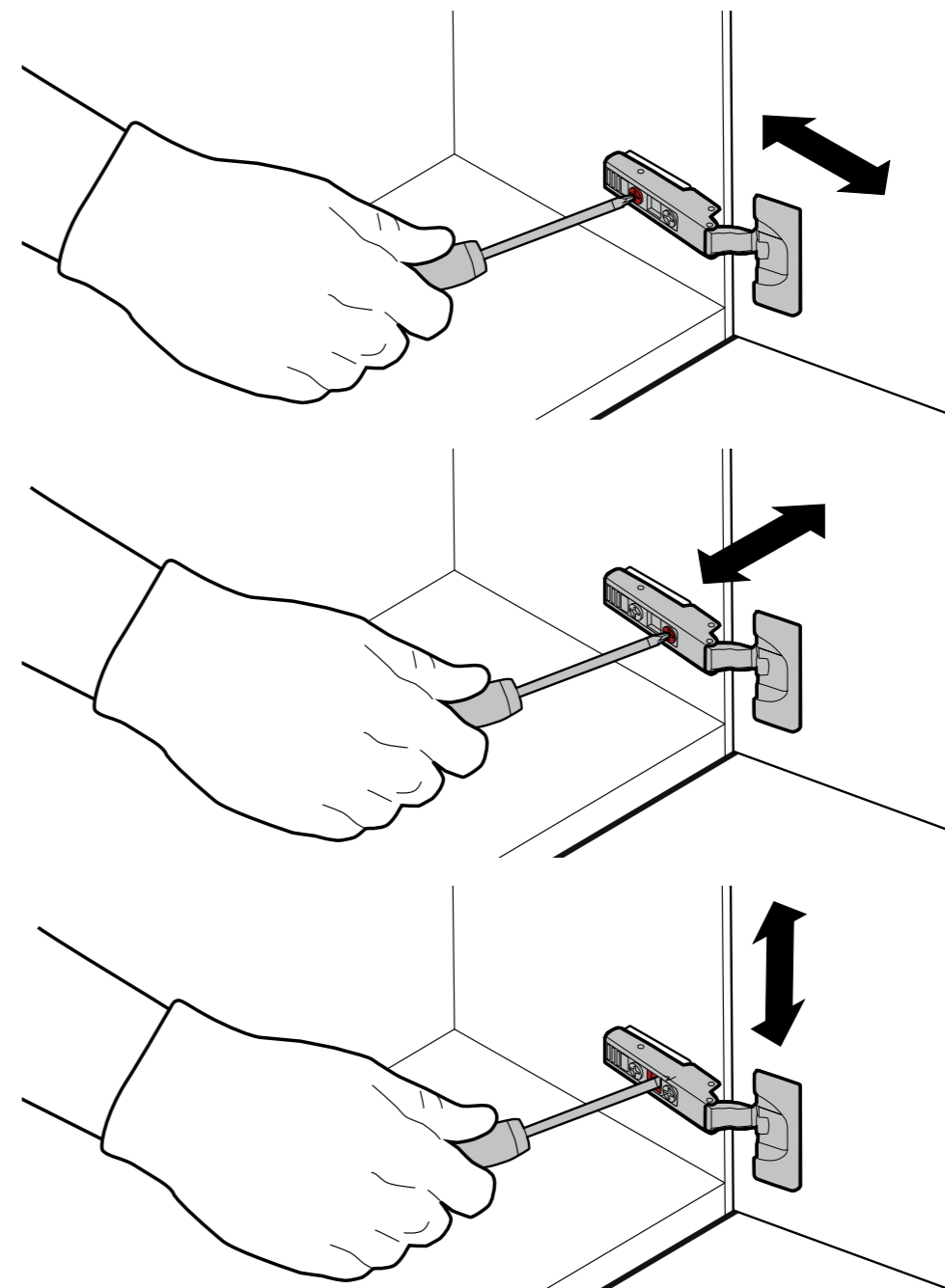

## how to repair Fenix NTM

surface defects caused by scratches can be removed either with the heat or with the magic sponge that you can request from your authorized LUBE / CREO dealer. For repairing, follow the instructions below:

### KITCHEN PAPER AND IRON REPAIRING

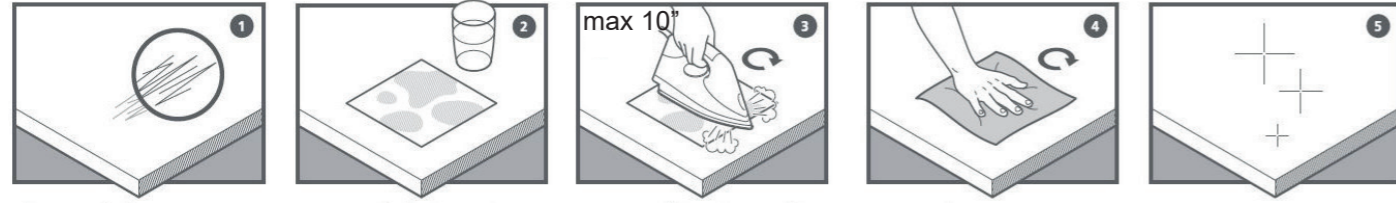

### MAGIC SPONGE REPAIRING

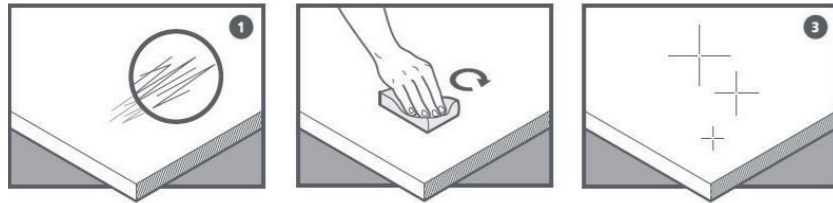

## how to remove / replace the drawer / deep drawer

 Pay attention to the weight of the drawer / deep drawer! Empty the drawer / deep drawer before removing it.

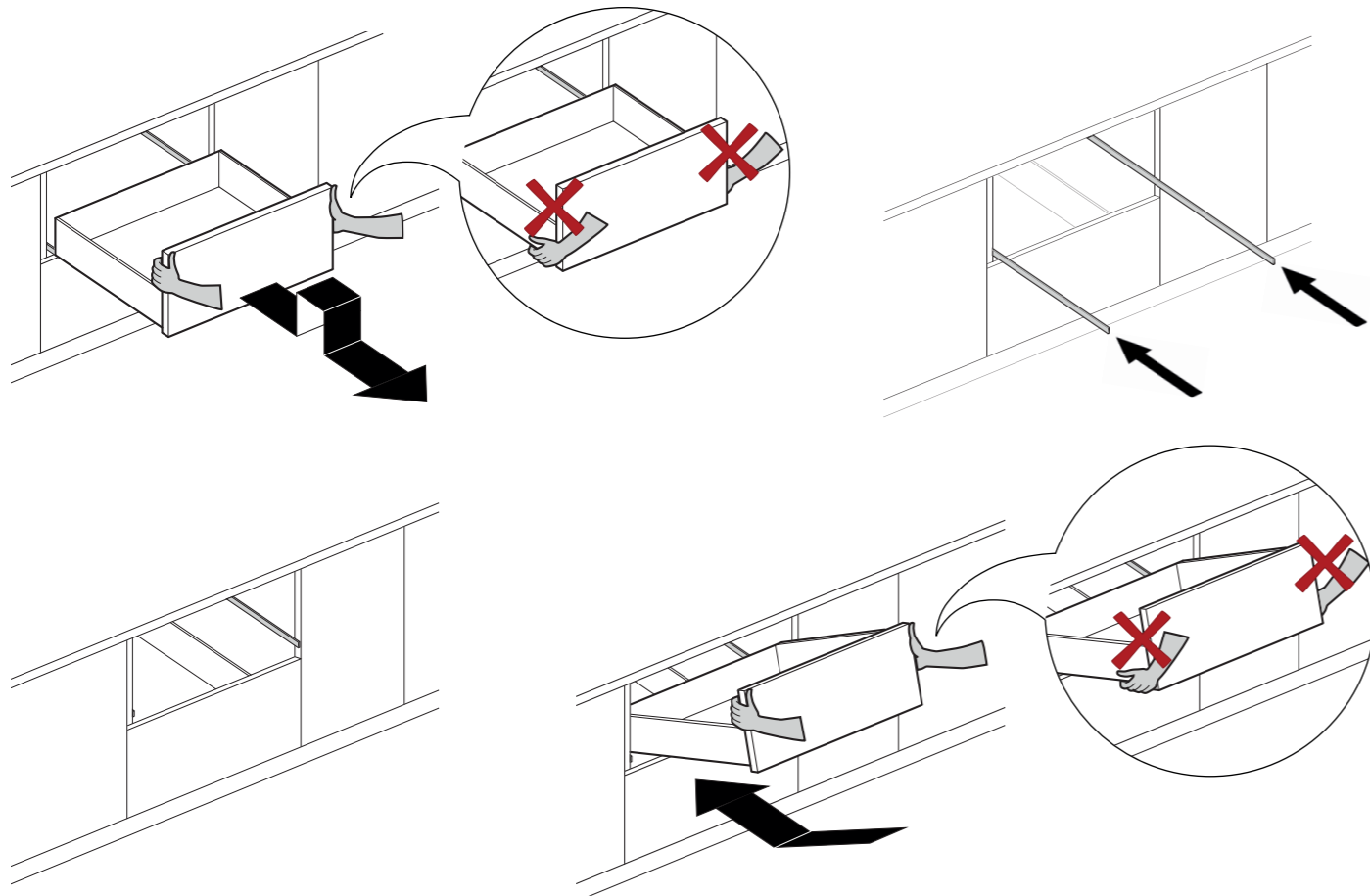

## how to adjust the drawer / deep drawer

The doors of the drawers and deep drawers can be easily adjusted with a screwdriver by acting on the appropriate registers. For making these adjustments properly, follow the steps below:

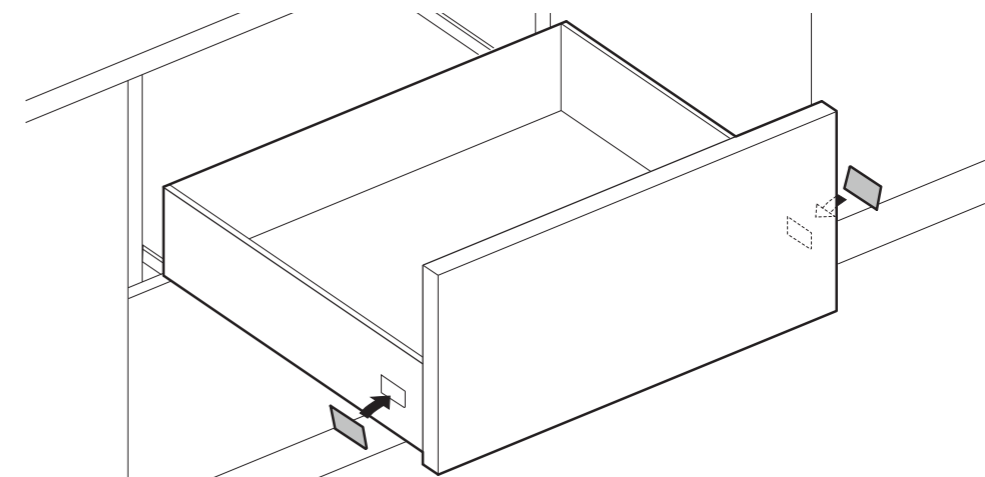
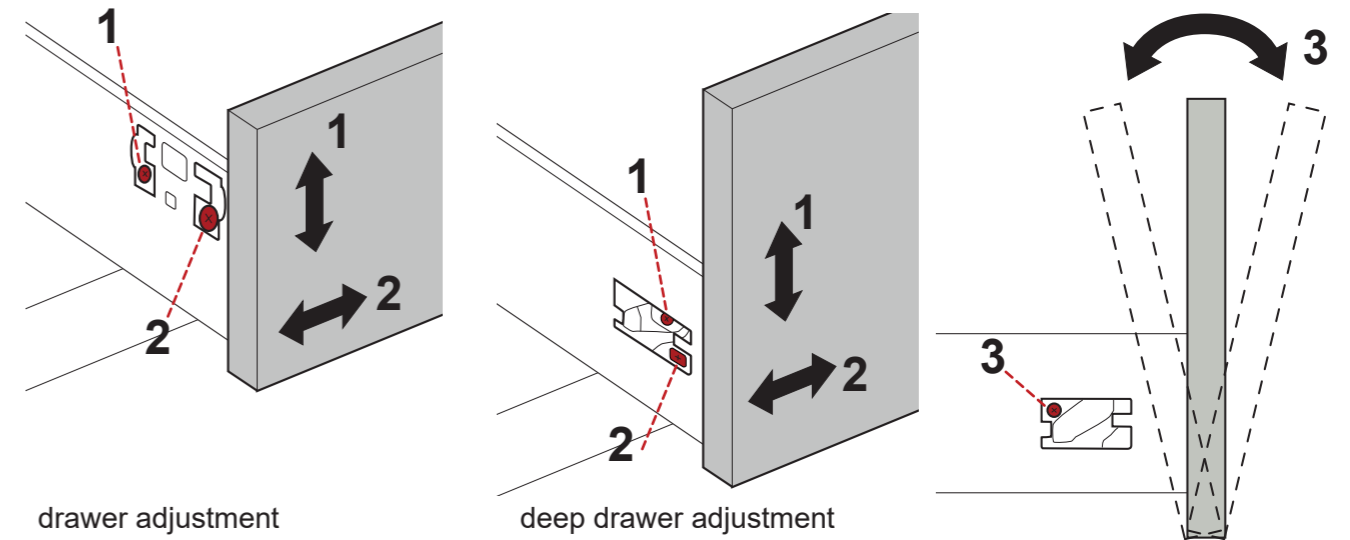
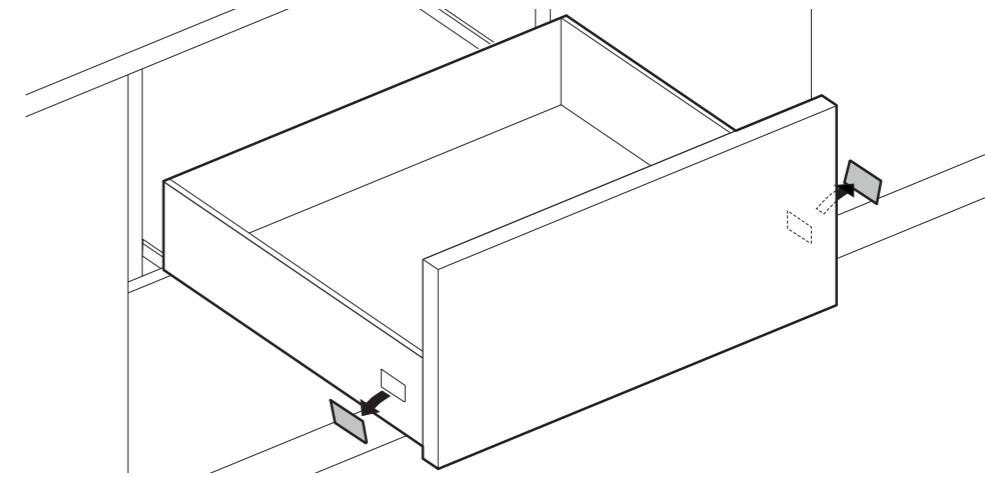

## how to unhook the plinth

To facilitate cleaning under the base units, it is possible to unhook the plinth simply by pulling it at the feet.

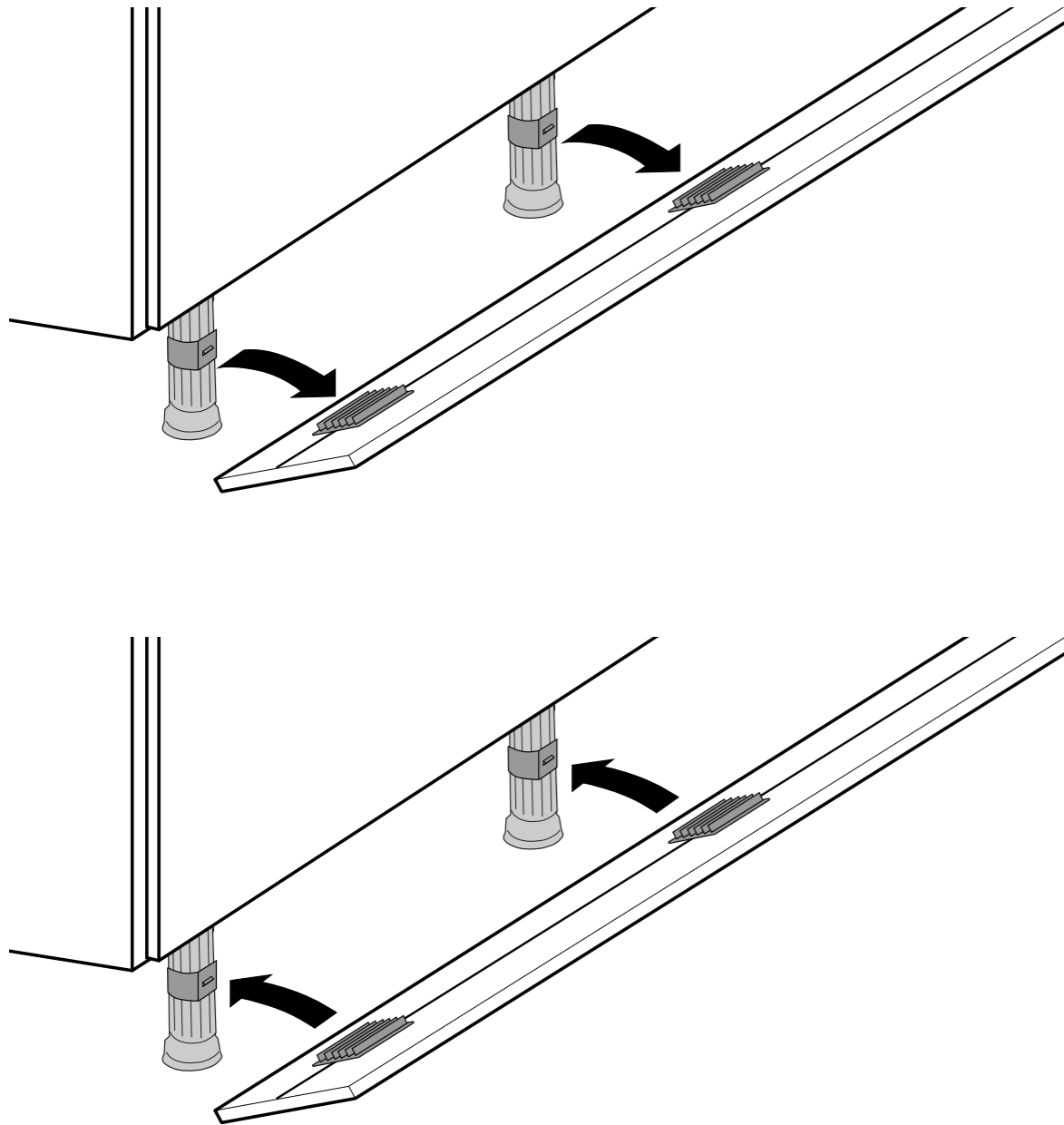

*For all other adjustments, contact your authorized LUBE / CREO dealer.*

## DISPOSAL

At the end of their use, do not disperse the furniture in the environment, but contact a municipal solid waste disposal company for their transport to landfill or recovery.



## ASSISTANCE

LUBE Industries srl makes use of selected and competent dealers who are able to resolve any problems that may arise after the purchase.

Requests for kitchen replacements or completions must be sent to your authorized dealer who will define and resolve the problem.



# GLOSSARY

## ABS

Acronym that stands for Acrylonitrile Butadiene Styrene, a polymer based on high-strength synthetic resins used in the construction of packaging, television sets, toys, etc.

## ACRYLIC

Acrylic is a thermoplastic material similar in appearance to glossy lacquered finish. It is also non-toxic, remains unchanged over time, retaining all its original characteristics of brilliance, and the colour does not yellow with age. It is resistant to ultraviolet rays and moisture. It is not resistant to the following products: acetone, ink and ethyl-butyl acetate.

## ACRYLIC PAINT

Paint with very high resistance to light that performs better with respect to yellowing. It is often used with light woods where any yellowing of the paint would cause a very unpleasant colour change. It gives the wood a very natural appearance as it can be applied with a minimum of thickness without creating the effect of covering the wood panel with a transparent film.

## ALKORCELL

It consists on a polypropylene-based (PP) decorative sheeting for indoor use free of halogen, plasticiser and formaldehyde. It is suitable for covering surfaces of wood-based materials and is used in the production of furniture components. A thermosetting paint gives the sheeting the properties necessary for these applications. For processes with different gluing systems, the sheeting is reinforced on the back with a primer and the gluing is done with dispersion or hot melt or solvent glues.

## ALUMINUM

Silvery white metal – malleable and very light – mainly used in aeronautics. Used both die-cast and drawn, it is then painted or protected by anodic oxidation processes, which makes the surface layers resistant to scratches and corrosion.

## BACK PANEL

Consisting of a 2.8 mm thick high density fiberboard in compliance with E1 and US EPA TSCA Title VI for the emission of formaldehyde ennobled in polypropylene for the wall units and painted for base and TALL UNITS.

## BACKSPLASH

Made of aluminum or rigid shockproof PVC with laminate decoration. Generally fixed on the worktop with screws and sealed with silicone both on the wall and on the part resting on the worktop.

## BOTTOM OF STRUCTURE FOR REFRIGERATOR (BASE UNIT, TALL UNIT)

Made of unalterable rigid plastic (PVC) material drilled in the center to allow any water leaks to escape and protect the furniture frame.

## CEMENT MORTAR

Cement mortar is a mixture derived from carefully studied mixtures of hydraulic and inert binders based on quartz flour and mineral sands with controlled grain size, free of salts and impurities. A percentage (1 ÷ 2%) of stabilizing elastomeric polymers is added to this formulation, to avoid tensions or cracks generated by temperature changes and particular dynamic stresses. Before application, the surfaces are treated in order to allow the application of the leveling compound. The latter is applied strictly by hand by expert craftsmen on composite panels. Once dry, several coats of transparent acrylic coating are applied: this treatment protects the surface from infiltrations of grease and dirt.

*For further information on USE / INSTRUCTIONS and CLEANING consult the relative chapters.*

## CENTRAL PANEL

The central panel of a door is generally made of veneered or covered chipboard.

## CHAIR / STOOL

Structure: made of tubular metal painted with thermosetting powders, or solid wood painted with water-based (impregnating) and acrylic / polyurethane (bottom) products.

Seat and Back: it can be made of synthetic material (methacrylate), solid wood, plywood, padded fabric or straw-like.

## CHIPBOARD (PANEL)

Defined by the technique as a panel of wood particles, it mainly exploits wood processing waste and the residual branches of trees; in this way, it becomes an ecological product, as it does not cause further felling of trees. It is composed of flakes and wood particles pressed and glued together with thermosetting adhesives. It is commonly used after veneering, ennobling with melamine paper or coating with PVC or laminate, materials that give the panel the desired aesthetic qualities.

It is much lighter than the MDF panel; however, it also has very low resistance to humidity, especially in the raw state. The materials with which it is normally coated, however, guarantee it a good resistance to water especially according to the type and methodology of the coating.

## CORNICE

Additional embellishment element usually inserted in classic kitchens. It can be in fir wood or MDF (class E1) veneered with wood veneer (different depending on the model); acrylic / polyurethane painting.

## COVER PANEL

Finishing element such as the door, inserted to compensate for the remaining spaces. Unlike the door, the band is generally of a much smaller width and remains closed.

## DISH DRAINER GRILL

Made of electro-welded metal wire, it can be plasticized with polymeric resin, nickel-plated, or chromed and covered with a plastic-coated transparent sheath (Crominox finish).

*For further information on max loads, see the SAFETY chapter.*

## DOOR

The door can be flat or with frame. The flat door can be in solid wood or covered with different materials (finishes): melamine, FENIX, wood (veneer), polymer, PET, Alkorcell, acrylic, glaks, wood, uv lacquered, lacquered, mortar, laminam stoneware, stoneware mutina, glass, decoration. if the door is covered, the internal support can be made of chipboard or mdf. the frame door, on the other hand, is composed of a solid wood or aluminum frame and a clew that can be in sheet metal, painted mdf wood, solid wood, glass or chipboard covered with: wood (veneer) or melamine.

*for further information on the ADJUSTMENTS see the relative chapter.*

## DOOR OPENING

The door can have different types of opening:

- DH/LH opening: "traditional" opening with vertical rotation axis and opening to the right or left
- opening with mechanism: very popular for the wall units, it can be divided into flapdoor opening, folding, oblique and vertical opening

## DRAWER / DEEP DRAWER FRONT DOOR

The door of the deep drawer can be flat or with frame, depending on the kitchen model. Instead, if lower than 23.7cm the drawer front door is always flat; it can be with frame only from 23.7 cm upwards.

*For further information on ADJUSTMENTS consult the relative chapter.*

## DRAWER / DEEP DRAWER INTERNAL STRUCTURE

The structure can consist of a base of 16 mm thick wood particle board (very low formaldehyde emission conforming to the F \*\*\*\* standard), faced in gray laminate with sides and back in galvanized and anti-corrosion painted steel sheet, or it can be entirely in solid beech and plywood; the sliding take place on full extension guides with interlocking system for anti-release locking and automatic closing invitation which acts in the last 4 cm. Furthermore, the closing slowing down system (blu-motion) is supplied as standard.

*For further information on the ADJUSTMENTS see the relative chapter.*

## EDGE

Edge in ABS or Polypropylene (PP) glued with thermosetting polyurethane glues 1 mm thick on the front parts of the cabinet side panels and shelves and 0.5 mm thick on the lower and upper parts of the cabinet side panels and on the sides and rear of the internal shelves. Paper for the non-visible parts of the cabinet (back).

## END UNIT

Element (base, wall unit, column) placed at the end of the composition. It is not mandatory, it only has an aesthetic function.

## FINGER RAIL OPENING

It consists of an anodized or powder coated aluminum profile. It can be "L" shaped or flat.

## FOOT LEG

Made of impact-resistant plastic (PVC), adjustable in height, it is screwed to the lower part of the cabinet by means of special bushes without drilling the bottom of the structure (thus avoiding completely points where dirt can accumulate or infiltrate water inside the base unit structures and under sinks).

It can also be in aluminum, adjustable and mounted on a special basement also made of an aluminum profile.

## FORMALDEHYDE

Formaldehyde is a substance used for the production of many adhesives and resins, which in turn are also used in the processing of wood panels. Panels produced in this way can release gaseous formaldehyde molecules into the environment. This emission, considered harmful to people's health, is regulated in many countries of the world by specific rules and laws.

The main ones are as follows:

- European legislation (E1)  
In Europe (for Italy Ministerial Decree 10/10/2008) the current limit is set at 0.1 ppm corresponding to formaldehyde class E1, obtained with testing methods EN 717-1:2004 or EN ISO 12460-3:2015.
- Japanese standard (F4\*\*\*\*)  
In Japan, the classification level of formaldehyde emissions is set by the Japanese standard JIS A 1460:2015 ranging from F\* to F\*\*\*\*. Currently, F\*\*\*\* (F4stars) is the world's most stringent regulation for the emission of formaldehyde (< 0.3 mg/litre, i.e. about half of the European E1).
- US legislation (CARB ATCM Phase 2/EPA TSCA Title VI)  
In California, which has always been the US state most attentive to issues of ecology and health, the law currently sets emission limits for all wood-based products. In particular, the ATCM CARB 2 Regulation requires limits to be within 0.09 ppm, according to the American standard ASTM E 1333-69 (2002) (large chamber method), so the California regulations are among the most stringent on the planet. Unfortunately, there is currently no official correlation between the values obtained with the ASTM method and the corresponding method used in Europe (EN 717-1 or EN 717-2). The products concerned must have third-party certifications issued by bodies authorized and recognized by the California Air Resource Board (CARB Phase 2 certification, also called CARB 2). Since 1 June 2018, the CARB limits for California have been extended by the United States Environmental Protection Agency (EPA) to all other federal states, so wood-based materials sold in the US must comply with CARB ATCM Phase 2 and EPA TSCA Title VI.

## FRAME

Full load-bearing structure, usually rectangular, made by joining four or more strips. If the frame is rectangular, the vertical elements are called uprights and the horizontal ones cross members.

## GLAKS

Organic glass with the same aesthetic characteristics as glass, but with a number of important advantages: it is unbreakable, resistant to scratches, chemicals and impacts. It can be worked with standard woodworking tools and machines and is available in custom sizes.

## GLOSS LEVEL

The level of gloss of the painted surface, using a special instrument called a glossmeter:

- Matt: up to 10 gloss units
- Semi-matt: from 11 to 35 gloss units
- Semi-glossy: 36 to 60 gloss units

- Glossy: from 61 to 80 gloss units
- Highly glossy: over 80 gloss units

## HANDLE

It can be on the front, on the top or integrated into the door. It is generally made of aluminum or zamak alloy with galvanic bath. The kitchen models with handles are named BRIDGE or HEAD.

## HANGING BRACKETS

Metal element for the wall fixing of the cabinet (wall unit, hanging base). Normally each piece of furniture is equipped with two hanging brackets, fixed on the inside part of the side panels and / or on the top panel.

## HEAT-FOUNDING GLUES

Adhesives that, applied in the molten state, glue thanks to their cooling and the pressure exerted between the two elements to be glued. They have reversibility characteristics, as if they brought back to temperatures that vary from 60 ° C to 100 ° C, they soften, temporarily losing their adhesive power.

## HINGE

In steel plate and copper and nickel-plated zamak alloy, anti-corrosion adjustable in three directions.

## HPL LAMINATE (COMPACT)

HPL stands for High Pressure Laminates. Laminates of this type are composed of layers impregnated with phenolic resin and a decorative covering impregnated with melamine resin, agglomerated under the combined effect of heat and high pressure, thus giving life to a product with exceptional qualities of hardness and resistance to scratches, wear, impacts, chemicals and fire. They are mainly used for worktops.  
*For further information on USE / INSTRUCTIONS and CLEANING consult the relative chapters.*

## JOLLY ELEMENT

Same as open unit but with variable height, width and height. The finish can be like the door or like the body.

## LAMINATE

It is made of phenolic resins (support) and melamine resins (decorative paper) glued together in such a way as to form sheeting of about 0.6 mm. It is used to cover wooden panels (laminated panels). Laminates

where the thickness of the support resins is bigger than 1 mm are defined as layered laminates (compact) which, thanks to their mechanical characteristics, can be used as self-supporting panels without being applied to wood panels.

## LACQUERING

Lacquering is a type of varnishing that uses lacquer, i.e. a coloured polyester and/or polyurethane covering that hides the veins of the wood, unless it is open-pore varnishing, i.e. a varnishing that colours and allows the veins of the wood underneath to be seen.

*For further information on USE / INSTRUCTIONS and CLEANING consult the relative chapters.*

## MELAMINE (PANEL)

Melamine is a solid and long lasting material made up of papers impregnated with melamine resin. This material must then be assembled to a chipboard panel to compose a finished material with which to create any type of furniture. Over the past few years, it has evolved both in aesthetic terms and in terms of functionality. By synchronizing the design with the matrix of the foil, this material faithfully reproduces the surface of various types of wood, creating very pleasant tactile and visual effects.

*For further information on USE / INSTRUCTIONS and CLEANING consult the relative chapters.*

## MELAMINE PAPER

Paper impregnated with melamine resins; it can be of various colors or imitate the grain of the wood. It is used for the coating of chipboard panels which after this treatment are defined melamine panels..

## MDF PANEL

MDF stands for medium density fibreboard and is made of branches and woodworking scrap. These panels are ecologically interesting because their production does not involve the systematic felling of trees. They are made up of wood fibres obtained by steam and special machines and then bound together with thermo-setting adhesives. Once pressed, these fibres (very similar to cotton wool) give the panel good mechanical characteristics, excellent dimensional stability and compactness along the edges, making it indispensable for the production of lacquered panels, veneered with PVC, and in cases where large surfaces are needed, where the wood could present problems of flatness. However, they have a high weight and generally low resistance to moisture.

## OPEN UNIT

Element (base unit, wall unit, tall unit) with variable height and width fixed and without door, therefore with exposed shelves. It can be in metal or wood in different finishes: polymeric, lacquered, melamine, based on the chosen kitchen model.

## PAINT THICKNESS

The thickness of the dry film of paint on a component is identified by measuring the thickness of the quality of paint applied:

Open pore: up to 5 microns thick

Semi-open pore: 6 to 20 microns thick

Semi-closed pore: 21 to 60 microns thick

Closed pore: over 60 microns thick

## PET

PET is the abbreviation of polyethylene terephthalate, a synthetic thermoplastic material that is part of the polyester family. It is a thermoplastic resin that is suitable for contact with food but it is also used in other areas, including the medical and cosmetic industries and more recently in the furniture sector. A product originally produced from petroleum or methane gas which can be recovered and endlessly transformed without losing its properties and resistance. Although its characteristics are similar to PVC, it has the great eco-friendly benefit, unlike polyvinyl chloride, of not producing any toxic substances during combustion. PET is thus a valued material that respects the environment and can easily be recycled and used to make excellent products. Doors covered in this material are made with MDF panels on which PET sheets are applied with a thickness varying between 0.3 mm and 0.4 mm, according to the type of finish.

## PLATING

Coating operation of a raw panel with various materials such as laminate, PVC, veneer etc.

## PLINTH

Made of anodized or painted aluminum, or PVC covered with decorated melamine paper. Standard heights: 6 cm or 13 cm.

## PLYWOOD (PANEL)

It is thus defined when five or more layers of wood are laid out with crossed fibers and fixed together with water and humidity resistant adhesives.

## POLYESTER PAINT

It is normally used where large thicknesses of paint are to be obtained with excellent mechanical strength (lacquered panels). Being harder than acrylic or polyurethane paints, it is normally used also on table tops and other elements subject to wear. It can be polished (glossy lacquered) with systems that require the use of increasingly finer grains, up to obtain a mirror surface with a great aesthetic effect. Even polyester paints have poor light resistance and are not suitable for producing very light lacquers that turn yellow easily.

## POLYPROPYLENE

Polypropylene (PP) is an environmentally friendly thermoplastic polymer with high quality production technology. It is also a product resistant to acids, solvents, light and moisture, characteristics that make it particularly suitable as an alternative to the more popular PVC and ABS.

## POLYURETHANE GLUES

PUR or polyurethane glues are widely used in the carpentry sector and form strong bonds that are resistant to crosswise stresses. It is therefore difficult to remove two elements glued with PUR without damaging them. Another important property of PUR adhesives is that they harden easily.

## POLYURETHANE PAINT

The most used in the wood sector because it is economical and easy to apply. As it has little resistance to light, it tends to turn yellow and is therefore not suitable for painting light-coloured wood.

## POSTFORMING LAMINATE

Application of a laminated surface on a substrate of irregular shape (usually curved or otherwise shaped), as with the machine edging of a panel.

## PVC

Polyvinyl chloride (PVC) is one of the most used plastic materials in the furniture industry, as they use it for coating both structural elements and doors. It is considered a toxic material, but in reality the dangers occur only in the production and destruction phases (if not burned in special incinerators it produces dioxins). It can be colored and can imitate the grain of the wood. Being a thermoplastic material, it does not resist much to heat, softening at temperatures between 75 and 95 ° C.

## SCREEN PRINTING

A special printing method where ink is passed through the mesh of a silk fabric (screen) except where the mesh has been blocked by an impermeable masking. When used on glass, the screen printing can be tempered at high temperatures so that it becomes indelible on the glass.

## SHELF

MELAMINE COATED SHELF: wood particleboard panel (class E1) ennobled in melamine; ABS edge.  
VENEERED SHELF: wood particleboard panel (class E1) veneered with wood veneer (different depending on the model) and painted with acrylic / polyurethane products.

LACQUERED SHELF: MDF panel (class E1) lacquered with solvent-based paints.  
PET SHELF: MDF panel (class E1 and EPA TSCA Title VI compliant) plated with PET and edged with ABS.

## SINK

**STEEL:** In 18/10 stainless steel sheet with single mold or with electro-welded tanks, smooth or "embossed" finish. The steel sink tends to highlight the water stains and limescale deposits which, however, can be removed through the normal specific products available on the market today.

**RESIN:** Composed of resins and mineral charges polymerized in the mold, it is impervious to chemicals and stains, but overtime it may lose elasticity and break following thermal shocks (e.g. cold water - hot water).

*For further information on USE / INSTRUCTIONS and CLEANING consult the relative chapters.*

## SINK CABINET BOTTOM COVERING

Made of squared aluminum or painted plastic, it protects the sink cabinet from water leaks.

## SPLASHBACK

Consisting of a panel placed above the top against the wall. Usually glued and sealed with silicone both on the wall and on the part resting on the top.

## STAINLESS STEEL

A steel that is resistant to corrosion and certain chemical agents. To be defined as such it must contain at least 12% of chromium. Stainless steel 18/10 means that it is 18% chromium and 10% nickel. Thanks to its hygiene it is often used in the food industry (pots, sinks, worktops).

## STRUCTURE AND SHELVES (BASE UNITS, TALL UNITS, WALL UNITS)

Made of panels of wood particles compliant with the standard F \*\*\*\* and US EPA TSCA Title VI (with very low formaldehyde emission), 18 mm thick, melamine coated.

The shelves are 18 mm thick and are equipped with built-in shelf support with anti-release device; they can also be made of tempered glass (6 mm thick), ground on the edges.

## TABLE

Top surface: it can be a panel of wood particles (class E1) covered with HPL plastic laminate (see laminate top) or veneered with wood veneer and painted with water, polyurethane or acrylic dyes, or it can be crystal, granite or stone natural.

Sides and base: they can be made of metal or laminated plywood panels or veneered with different wood veneer, depending on the model.

Legs: they can be made of metal or solid wood; painting is performed with acrylic / polyurethane products. For further information on USE / INSTRUCTIONS and CLEANING consult the relative chapters.

## TEMPERED GLASS

Glass with special hardness and impact resistance obtained through tempering. This process consists in heating the glass to high temperatures (650°C) and then cooling it rapidly by blasting it with jets of air.

## THERMOSETTING GLUES

Resins that exert their bonding power thanks to chemical reactions that are partly activated by heat. The most important ones in the furniture industry are obtained by combining formaldehyde and other base resins. Having undergone a chemical reaction, they are irreversible adhesives and therefore resist even high temperatures. The polyurethane adhesives used by Lube to glue the edges of the drawers are of this type.

## UV LACQUERING

A type of coating (lacquering) where the products applied are hardened thanks to irradiation carried out by special lamps that emit high-energy ultraviolet light. These systems allow for a very quick and effective hardening of the resins, which normally produce very hard and resistant films.

For further information on USE / INSTRUCTIONS and CLEANING consult the relative chapters

## VENEER

A thin sheet of wood (about 0.6 mm) cut from tree trunks. It is used to cover wood panels (MDF, chipboard, solid wood, etc.), which are then referred to as veneered.

## VENEERED WOOD

Wood panel (MDF, chipboard, etc.) covered with veneers (see item VENEER on glossary). Veneered wood can be the panel of a door, a shelf or even a part of a worktop (peninsula, snack surface, island).

For further information on USE / INSTRUCTIONS and CLEANING consult the relative chapters.

## WATERPROOF PANEL

In the furniture sector, the term waterproof refers to those “raw” chipboard, MDF or multilayer panels that resist, for a certain period (established according to regulations) to the swelling caused by water in the wood fibers.

This resistance is not absolute and there is a scale of values; the maximum resistance value corresponds to the definition of a water-repellent panel. Of course, other factors such as the type of melamine and gluing / sealing of the edges contribute to the water resistance of the panels.

## WATER-BASED PAINT

Used for new ecological painting systems where the solvent used is water. This solves significant environmental problems (just think that in some cases during drying as much as 70% of the product applied evaporates in the form of polluting solvents). Water-based paints are still in the experimental phase.

## WOOD

Wood is taken from tree trunks. It is, therefore, a natural material with all the characteristics this implies. Differences in grain or shade between the different parts cannot therefore be considered as a cause for complaint. Cucine LUBE has nonetheless included strict controls on wood finishes and combinations in its Quality System, in order to reduce any problems to a minimum. Exposure of wood to direct sunlight may cause entirely normal changes in colour, linked to the natural change in the material. The wood matures over time and may turn a slightly different shade, which should not be considered as a defect. It should be remembered that, even after processing, it behaves like a living product, changing in volume as the humidity in the surrounding environment changes.

## WORKTOP - CERAMIC (DEKTON, INFINITY, IRIS, KERLITE, LAMINAM, LAPITEC, MUTINA)

The ceramic worktop is a sophisticated mixture of gres porcelain composed of clays and precious raw materials. The compound is pressed and sintered in innovative ovens at very high temperatures (around 1200 ° C). It is produced in slabs of reduced thickness and large dimensions (even 300x100 cm). The individual slabs have excellent resistance to heat, stains and scratches, ultraviolet rays and abrasion. They are incorruptible from time and weather.

The worktop surface is totally anti-absorbent, free of porosity, moreover dirt, bacteria, fungi or mold pathogens absolutely cannot penetrate inside the surface material of the product.

For further information on USE / INSTRUCTIONS and CLEANING consult the relative chapters.

## WORKTOP - COMPOSITE (DUPONT CORIAN, ILE LUBE, LAB LUBE, LIGHT, OKITE, QUARTZ, SILESTONE)

The composite worktop is the result of a mixture composed of natural powders such as quartz (over 90%), resin and colored pigments. This composition guarantees high technical performances on the floor. The material is not porous, it is waterproof, resistant to stains, acids and solvents, to the absorption of liquids, to heat. It is also resistant to abrasion and chemical attack. The surface of the composite worktop slab may present some micro-particles of different coloring due to the result of a mixture composed almost entirely of natural quartz, this does not mean that the product can be considered non-compliant with the natural quality standard and therefore contestable.

The main feature of the Dupont Corian worktop is that this material is composed in a greater percentage than the other tops made of acrylic resins. For this reason Corian is a material that can be restored, taking any shape you want at controlled temperatures.

For further information on USE / INSTRUCTIONS and CLEANING consult the relative chapters.

## WORKTOP - FENIX NTM

Manufactured thanks to new generation resins, this intelligent material stands out for a surface with extraordinary properties.

With low light reflection, its surface is extremely matt (specular reflection value: 1.5 and 60°) and anti-fingerprint. Thanks to the use of nanotechnology, it is soft touch and any micro scratches can be thermally repaired.

*For further information on USE / INSTRUCTIONS and CLEANING consult the relative chapters.*

## WORKTOP - GLASS

The main feature of the glass tops is to combine a strong aesthetic impact with hygienic guarantees done by the non-porosity of the surface, torsional and impact resistance and also the high resistance to deterioration and aesthetic decay over time. The used materials are the following:

- 1) 12 mm thick glass
- 2) Support in class E1 water-repellent V100 melamine, 28 mm thick
- 3) Aluminum edge
- 4) Lacquering performed with lead-free paints
- 5) Special glues

## WORKTOP - GRANITE

It is one of the most abundant rocks on the earth's surface. It is an intrusive igneous rock (it originates when magma remains trapped in the earth's crust, solidifying at depth). Its name comes from the Latin granum (grains), with clear reference to its holocrystalline structure (granular), so from an aesthetic point of view the granite presents itself in grains. It is mainly composed of quartz (between 20 and 60%) and therefore contains hard materials.

Polishing: quite durable; good resistance to wear and contact with chemicals.

Absorption: like all natural stones, liquids penetrate the porosity of the material; some of them (like water) cause a wet effect that vanishes with evaporation; others (such as oil and other fatty substances) leave permanent dark halos.

Break resistance: high. The stones are particularly noble materials for their natural origin, but also for the beauty and preciousness that make these products unique pieces, never equal to themselves: for this reason each supply will have color characteristics (shades, streaks, grains) and different features from the others (difficult to perceive only by evaluating a color swatch at the time of sale). Therefore none of these peculiarities can be perceived as defects: they should rather be interpreted as signs of uniqueness.

*For further information on USE / INSTRUCTIONS and CLEANING consult the relative chapters.*

## WORKTOP - HPL COMPACT

Laminate worktop without panel of wood particles as support, consisting only of overlapping layers of Kraft paper impregnated with thermosetting amino-plastic resins compliant with EN 438 and ISO 4586 standards. It is subjected to a high-pressure process at 9 MPa and 150 ° C in special multi-compartment presses, where the poly-condensation of the resins takes place so as to obtain a non-porous material. It has a fixed thickness of 12mm.

*For further information on USE / INSTRUCTIONS and CLEANING consult the relative chapters.*

## WORKTOP - LAMINATE

The laminate worktop consists of a water-repellent panel of wood particles (class E1) covered with high pressure plastic laminate (HPL).

It boasts exceptional characteristics of mechanical, physical and chemical resistance, easy workability and great simplicity of maintenance.

The manufacturing process of this top gives life to a stable, homogeneous, non-porous, high density material with physical and chemical characteristics totally different from those of its original components, moreover, given its very low permeability, high compactness and little porosity thanks to the melamine resin of which it is composed, it is not affected by food and chemical agents commonly used in the home; HPL is a thermosetting material, it does not react with these substances and, being very hygienic, it constitutes a barrier against possible formaldehyde emissions, growth of bacteria, molds, fungi and other volatile substances (VOC) coming from any wooden substrates that plays. It also has exceptional qualities of hardness and resistance to scratches, impacts, abrasions, chemical agents and heat.

*For further information on USE / INSTRUCTIONS and CLEANING consult the relative chapters.*

## WORKTOP - MARBLE

Marble is a metamorphic rock composed mainly of calcium carbonate (CaCO<sub>3</sub>), therefore it contains semi-hard materials. This material is formed through a metamorphic process from sedimentary rocks, such as limestone or dolomite, which causes a complete recrystallization of the calcium carbonate of which they are mainly composed. From an aesthetic point of view, marble looks like a homogeneous paste.

Abrasion resistance: Not very high, any scratches can be mitigated by using floor wax.

Polishing: durable; as long as there is no frequent rubbing on the surface; avoid contact with acid-based chemical agents.

Absorption: like all natural stones, liquids penetrate the porosity of the material; some of them (like water) cause a wet effect that vanishes with evaporation; others (such as oil and other fatty substances) leave permanent dark halos. Acid substances (vinegar, lemon, etc.) adversely affect polishing.

Break resistance: quite high.

The stones are particularly noble materials for their natural origin, but also for the beauty and preciousness that make these products unique pieces, never equal to themselves: for this reason each supply will have color characteristics (shades, streaks, grains) and different features from the others (difficult to perceive only by evaluating a color swatch at the time of sale). Therefore, none of these peculiarities is a defect: it is a sign of uniqueness.

*For further information on USE / INSTRUCTIONS and CLEANING consult the relative chapters.*

## WORKTOP - MARBLE OR GRANITE AGGLOMERATE

It is a compound based on marble or granite (about 95%), resin and colored pigments, made with a patented high-tech process. It is a rather porous material, like natural stones.

*For further information on USE / INSTRUCTIONS and CLEANING consult the relative chapters.*

## WORKTOP- STEEL

The stainless steel worktop is composed of a support of wood particles (Class E1) covered with AISI 304 2B steel sheet with 1 mm thick scotch brite finish; it is perfectly resistant to stains and has characteristics

of absolute suitability for the hygienic treatment of food in the kitchen. A great advantage of this top is that you can directly weld the sink basins and the hob, obtaining continuity and avoiding junction points that can retain dirt.

*For further information on USE / INSTRUCTIONS and CLEANING consult the relative chapters.*

## **ZAMAK**

Alloy made of pure zinc, aluminum and magnesium, which in addition to being significantly inert from a chemical point of view, lends itself very well to the processes of die-casting. In the furniture sector it is used mainly for the production of knobs and handles.



